



BATTEURS MELANGEURS - GRANDE CAPACITE - VARIATEUR DE VITESSE PLANETARY MIXERS - LARGE CAPACITY - MULTI SPEED SYSTEM

CE

**MULTI-ACTIVITÉS
ALL PURPOSE**

Fourni avec :
Supplied with:

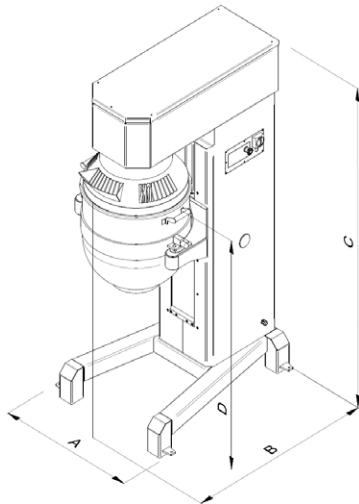

BTAxFH

Variateur de vitesse
Tableau de commande digital
Minuterie

Levage de cuve motorisé
Cuve inox renforcée et outils inox
Blocage de cuve
Grille de sécurité rotative
Bec verseur sur grille
Mise à niveau réglable, patins anti-vibrations
Pieds en inox peints
Roulettes fixes

OPTIONS

- Equipements de réduction
- Racléur de cuve
- Chariot de cuve
- Elevateur de cuve
- Corps de machine en inox
- Tableau de commande tactile programmable

BTAxFH

Multi speed system
Digital control panel
Timer

Motorised bowl lifting
Stainless steel strengthened bowl and stainless steel tools
Locking bowl
Rotary safety grid
Spout on grid
Adjustable level, anti-vibration pads
Stainless steel painted feet
Fixed castors

OPTIONS

- Additional equipments
- Bowl scraper
- Trolley for bowl
- Bowl lifter
- Stainless steel body
- Programmable touch screen control panel

	BTA80FH	BTA100FH	BTA120FH	BTA140FH
Capacité de la cuve / Bowl capacity				
Litres	80	100	120	140
Dimensions / Dimensions				
A mm	920	920	920	920
B mm	1250	1250	1250	1250
C mm	2085	2085	2085	2085
D mm	1490	1490	1490	1490
Poids / Weight				
Kg	607	612	631	635
Puissance moteur / Motor power				
kW	3	3	4	4
Voltage / Voltage	TRI - 400V - 50/60Hz			

caplain
machines

999 Rue du Tuboeuf - BP.99 - 77170 Brie Comte Robert - FRANCE

Tel. +33.1.60.02.19.19 - Fax. +33.1.60.28.91.42

www.caplainmachines.com - export@caplainmachines.com - info@caplainmachines.com